

### Roller Conveyor

### Heavy duty weighing

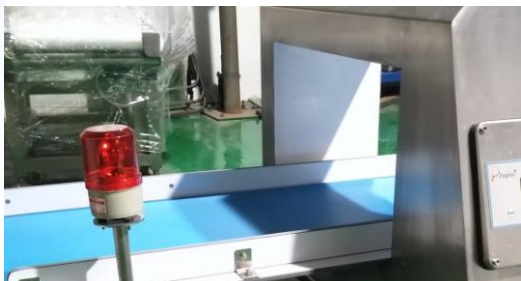

#### Flexible product handling

Customizable with more than 100 performance and productivity enhancing options.

Vibration-decoupled sorting/rejecting devices and specialized guide rails ensure flawless product flow.

#### Performance in harsh environment

Designed for endurance and maximum reliability in moisture and dry working environments.

Specialized food grade conveyor rollers allow regular cleaning routines to maintain hygiene standards.

#### Metal detector integration

Available with a metal detector input contact to trigger optional rejecting devices or allow conveyor shutdown for contaminated products. Ideal for use as a Critical Control Point for best quality and safeguarding brand reputation.

#### Double direction adjustability

A flexible mechanism of conveying direction adjustability enables the machine installed on line without considering the left right conveying direction adaptability.

### Optional spare parts and components

Infeed roller conveyors

outfeed roller conveyors

Ink printer integration available for optimal usability

Rejecting equipment e.g. pusher to ensure efficient removal of rejected products

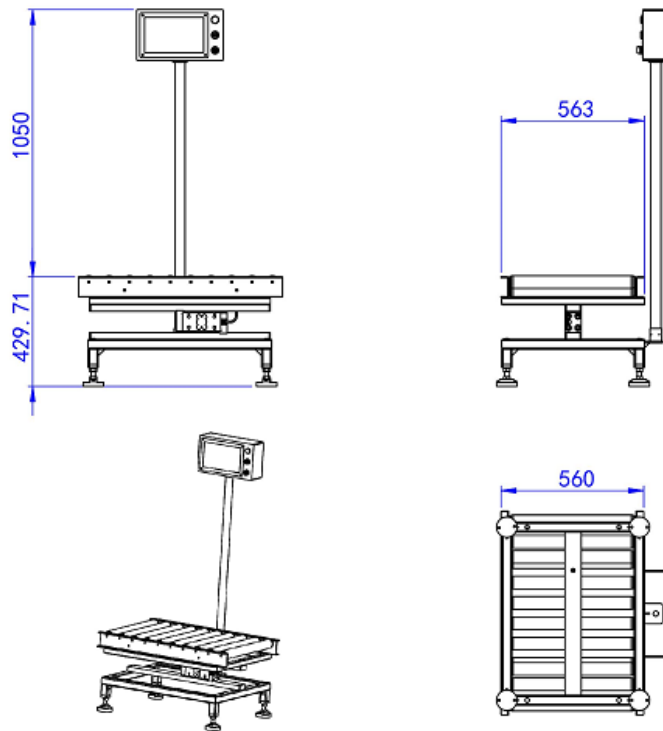

### Roller Conveyor Heavy Duty

For High Loads in Demanding Environments

A semi automatic product feeding system, a weighing range up to 100 kg and very high weighing accuracy positions the RCW-500 at the forefront of heavy load checkweighing technology.

The robust performance of this checkweigher allows its use in near to all industrial production situations, especially those where demanding high load application requirements need to be achieved in challenging working environments. It has been designed to fulfill the most demanding system integration requirements and can be utilized not only for end of line completeness checking but also for 100 percent weight control of single large products.

### Detailed technical specification

Max weighing range		30kg / 50kg / 60kg / 100kg
Best accuracy*		from ± 5 g to 10 g
Speed capacity*		Worker manual feeding
Panel		Touch screen (10 inches)
Product memory		100 kinds of products
Roller Weigher	Length	800mm
	Width	500mm
Conveyor height		450mm+-50mm(other height optional)
Working function		Green light is on when weight is OK Red light is on and together with siren alarm when weight is not good
Rejection system		Light and siren alarms / Automatic pusher rejector
Power Supply		12V DC / 24V DC / 220V
Ingress rating		IP65
Frame material		Stainless steel 304

\* Within official margins of error, depending on the weight, dimensions and transport characteristics of the product being weighed

### Ernest Fleming Machinery and Equipment Pty Ltd

Factory 7, 27 Mars Road LANE COVE WEST NSW 2066 AUSTRALIA

TEL: 0061-2-94273270 www.fleming.com.au sales@fleming.com.au